

# AVERY DENNISON MARKETING SPECIFICATION

## HISTORY

THE SUBJECT MATTER DISCLOSED HEREIN EMBODIES PROPRIETARY INFORMATION WHICH IS THE CONFIDENTIAL PROPERTY OF THE AVERY DENNISON CO. NONE OF WHICH SHALL BE COPIED, REPRODUCED, DISCLOSED TO OTHERS, PUBLISHED OR USED IN WHOLE OR IN PART, FOR ANY PURPOSE OTHER THAN THAT FOR WHICH IT IS BEING MADE AVAILABLE WITHOUT THE EXPRESS ADVANCE WRITTEN PERMISSION OF A DULY AUTHORIZED AGENT OF THE COMPANY. THIS DOCUMENT IS THE PROPERTY OF THE AVERY DENNISON CO. AND IS TO BE RETURNED TO THE COMPANY ON DEMAND.

REV.	DATE	DESCRIPTION
B	04.17.19	UPDATES TO NEW FORMAT; ADDED -0 TO PART NUMBER; ADDED SPECIAL CHARACTERISTIC NOTE; ADDED RECOMM. STRAP CUT LENGTH VIEW

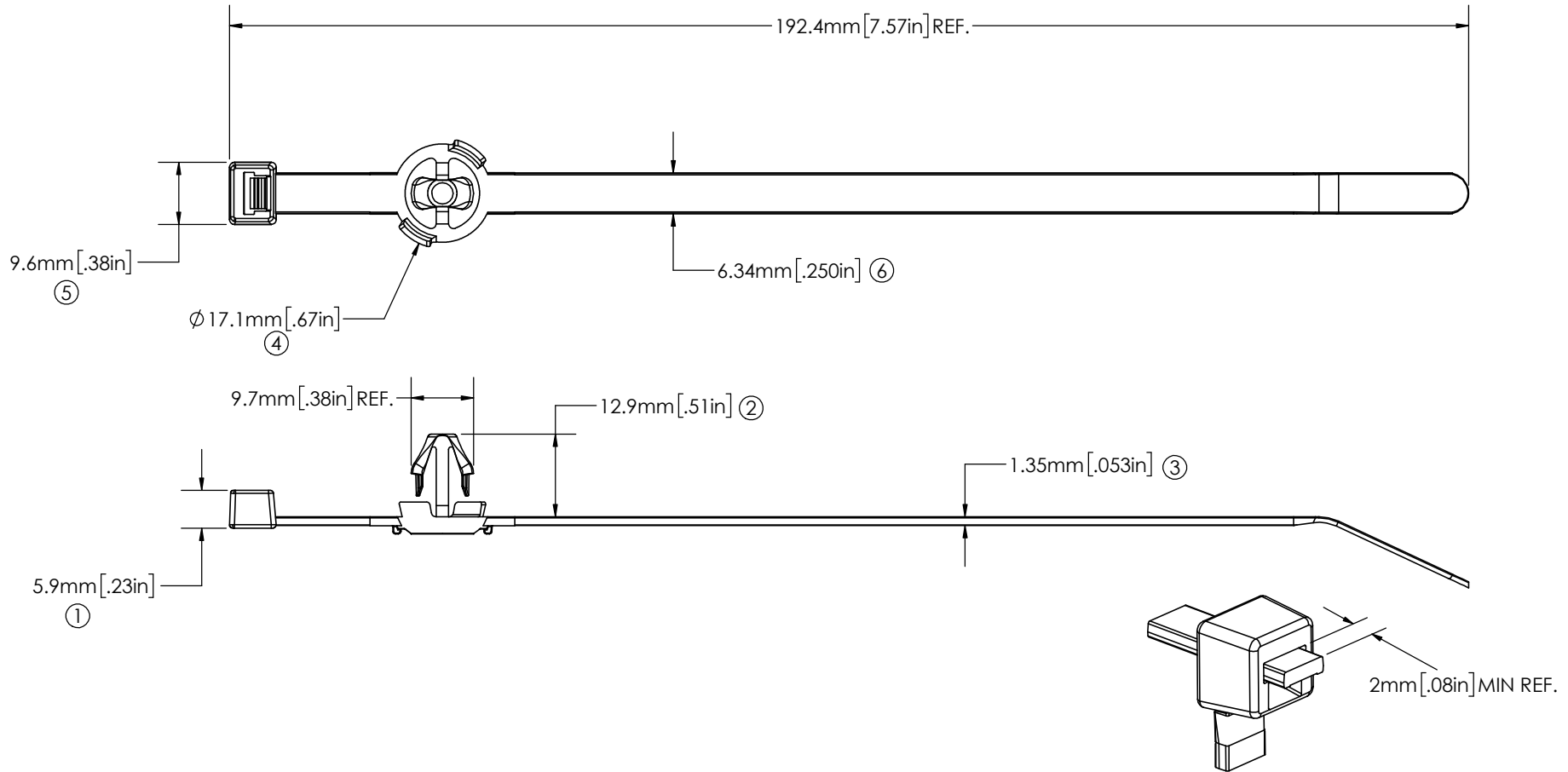

**RECOMMENDED  
CUT LENGTH**

⑦	△	FLAMMABILITY:	HB RATED PER FMVSS302
⑧	△	TENSILE STRENGTH:	222N / 50 lbf MIN.
		MOUNTING:	6.6mm HOLE
		OPERATING TEMP RANGE:	-40°F (-40°C) TO 239°F (115°C) CONTINUOUS AND 257°F (125°C) AT MAXIMUM EXPOSURE
		WEIGHT:	1.94g
		BUNDLE DIAMETER:	∅ 1.6mm [.06in] TO ∅ 44.5mm [1.75in]
		TOOL:	12001 - HAND TOOL 12500 - PNEUMATIC TOOL
		TOOL TENSION SETTING:	6 - 8
		PACKAGING:	500/BAG, 10 BAGS/MASTER

**NOTES:**

1. △ = INDICATES SPECIAL CHARACTERISTIC

**APPROVALS:**

ENG. APPR.	<i>Daniel Gilbertson</i>	04.17.19
Q.A. APPR.	<i>Rick Estano</i>	04.17.19

**SPECIFIED TOLERANCES ARE:**

.XX ± .03 INCHES	.X ± .7 mm
.XXX ± .010 INCHES	.XX ± .25 mm
ANGULAR: ± 2°	

MATERIAL	<b>NYLON 6/6, IMPACT MODIFIED, HEAT STAB.</b>
COLOR	<b>BLACK</b>



FASTENER DIVISION  
FITCHBURG, MA 01420 U.S.A.  
TEL. 1-800-225-5913  
FAX. 978-353-8157

DESCRIPTION	<b>90° ARROW TIE, BLACK</b>	
PART NO.	<b>20087-0</b>	REV. <b>B</b>